

#

Technical Report – R4791035862 BS 6375-2:2009 - Performance of Windows and Doors, Classification for operation and strength characteristics and guidance on selection and specification

**Orbit Design Limited
20” (508mm) Diamond Link Hinge
Top Hung Window**

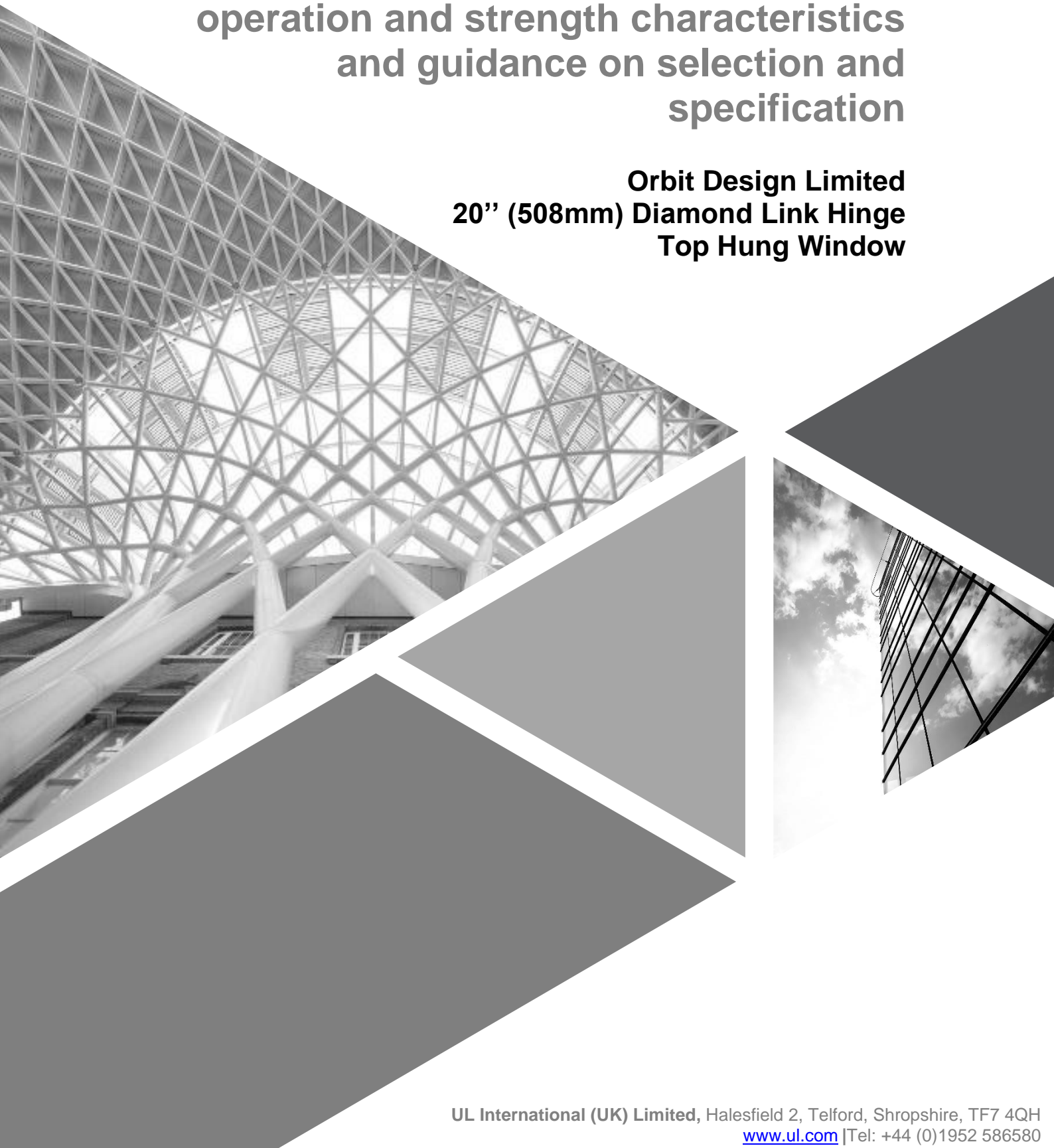



Contents

1. Introduction2
2. Summary of Results3
3. Description of Test Sample4
4. Test Arrangement7
5. Test Procedures8
6. Test Results10
7. System Drawings14

1. Introduction

This report describes tests completed to determine the durability, with respect to operating forces, mechanical strength and resistance to repeated operation, of the test specimen supplied:

Test Details	
Customer:	Orbit Design Limited The Walnuts, Ingleby Road Stanton by Bridge DE73 7HU GB
Product Tested:	20" (508mm) Diamond Link Hinge Top Hung Window
Date of Sample Received:	6 th October 2023
Date of Test:	Mechanical Strength: 16 th November 2023 Repeated Opening and closing: 12 th October – 25 th October 2023
Test Conducted at:	UL International (UK) Limited Halesfield 2 Telford Shropshire TF7 4QH
Test Conducted by:	S Ward <i>Engineering Technician</i> C Holden <i>Laboratory Technician</i>

Report Authorisation	
Report Compiled by:	T Smith <i>Engineering Project Handler</i> 
Authorised by:	R Cadwallader <i>Engineer Project Associate</i> 

UL International (UK) Limited is accredited by the United Kingdom Accreditation Service as UKAS Testing Laboratory No. 5772.

REPRODUCTION OF THIS DOCUMENT IN WHOLE OR ANY PART THEREOF MUST NOT BE MADE WITHOUT PRIOR WRITTEN PERMISSION FROM UL INTERNATIONAL (UK) LIMITED.

This report and the results shown within are based upon the information, drawings, samples and tests referred to in the report. The results obtained only apply to the sample tested and do not necessarily relate to samples from the production line of the above-named company and in no way constitute any form of representation or warranty as to the performance or quality of any products supplied or to be supplied by them. UL International (UK) Limited or its employees accept no liability for any damages, charges, cost or expenses in respect of or in relation to any damage to any property or other loss whatsoever arising either directly or indirectly from the use of the report.

2. Summary of Results

The table below summarises the results of testing carried out to the relevant standard and compared to the relevant criteria:

Test Method & Classification Standard	Description	Classification
BS EN 12046-1: 2003 BS EN 13115:2001	Operating forces	Class 1
BS EN 13115:2001	Mechanical Strength	Class 3
BS EN 14608: 2004 BS EN 13115:2001	Racking	600 N
BS EN 14609: 2004 BS EN 13115:2001	Static torsion	300 N
* BS EN 1191:2000	Repeated opening and closing	Class 3

More comprehensive details are reported in Section 6.

Note: *These results are valid only for the conditions under which the test was conducted.*

All measurement devices, instruments and other relevant equipment were calibrated and traceable to National Standards.

* **Hinge fixing:**
 PH2 Cheese head Gimlet point 4.8 x 25mm, SFG 4.8 x 25 S screws were used for Repeated opening and closing.

For all other tests, PZ2 4.8 x mm x 60 mm A2 Stainless steel tapping screws were used.

See the product description for further details.

2.1 Decision Rule

Classifications reported in Section 6 indicate that the product conforms with the relevant accuracy requirements of the testing standards (as summarised below) and the expanded measurement uncertainty ($k=2$ for approximately 95% coverage probability) is no greater in magnitude than the accuracy requirements defined in Section 2 of BS EN 947 - 1999, BS EN 948 - 1999, BS EN 949 - 1999, BS EN 950 - 1999, and Section 5 of BS EN 12046-1 - 2003 and/or BS EN 12046-2 - 2000.

2.2 Measurement Uncertainty

The reported expanded uncertainty is based on a standard uncertainty multiplied by a coverage factor $k=2$, providing a level of confidence of approximately 95%, and for the operating forces is $\pm 0.47\%$, for mechanical strengths is $\pm 0.37\%$ and for indentation during impacting is $\pm 0.30\%$.

3. Description of Test Sample

The details shown in section 3 and drawings shown in section 7 have been supplied by and confirmed as typical of normal production by Orbit Design Limited and have not been verified by UL International (UK) Limited.

See Section 7 for sample drawings as supplied by Orbit Design Limited.

Product range name:	Diamond Link Hinges
Project name to appear on front page of the test report:	20" (508mm) Diamond Link Hinge
Configuration:	20" (508mm) Diamond Link Hinge 16.5mm stack height
Opening direction:	Top Opening (As viewed from the inside)
Product manufacturer:	Orbit Designs Ltd
Is the sample typical of normal production?	Yes
Please define the closing condition of the sample: i.e. closed, fastened, latched, locked and secured etc.	Closed and locked
Weight of Sample including subframe (kg):	55kg Approximately
Weight of Sash (kg)- applicable for sample tested with accordance with BS 6375-2:2009	40kg

Outer Frame			
Outer frame width:	950mm	Outer frame material:	UPVC
Outer frame height:	1200mm	Outer frame gasket:	EPDM
Outer frame Part Numbers		Gasket type:	Standard Co-Extruded
Top:	EWS 7721	Manufacturer:	Eruocell
Bottom:	EWS 7721	Product name:	Logik 70 Ovolo Main Frame
Lock side:	EWS 7721	Product code:	EWS7312
Hinge side:	EWS 7721	Threshold	No Threshold
Outer frame section size		Manufacturer:	NA
Width:	70mm	Product name:	NA
Depth:	60mm	Product code:	NA
Reinforcing:		Material:	NA
Manufacturer:	Eorocell	Outer frame joint method	
Product name:	Frame Reinforcement	Head:	Welded
Product code:	EWS 7621S	Foot:	Welded
Material:	Steel	Surface Finish	White/Smooth

Leaf			
Leaf/Casement width:	850mm	Leaf/ Casement material:	UPVC
Leaf/ Casement height:	1100mm	Leaf/ Casement gasket	EPDM
Leaf/ Casement Part Numbers		Gasket type:	Standard Co-Extruded
Top:	EWS 7705	Manufacturer:	Eurocell
Bottom:	EWS 7705	Product name:	Logic 70 Ovolo T Sash
Lock side:	EWS 7705	Product code:	EWS 7705
Hinge side:	NA	Leaf midrail:	No Midrail
Leaf/ Casement section size		Manufacturer:	NA
Width:	75mm	Product name:	NA
Depth:	70mm	Product code:	NA
Reinforcing:	NA	Material:	
Manufacturer:	Eurocell	Leaf/Casement joint method	
Product name:	Sash Reinforcement	Head:	Welded
Product code:	EWS 7604S	Foot:	Welded
Material:	Steel	Surface Finish	Smooth White
Glazing			
Glass unit	MDF Weighted Panel	Glazing gasket	
Manufacturer:	NA	Gasket type:	Co Extruded
Inner thickness:	NA	Manufacturer:	Eurocell
Spacer material:	NA	Product name:	Logic 70 Ovolo Bead
Outer thickness:	24mm	Product code:	EWS7312
Unit sizes:	1320mm x 920mm	Glazing clip	No Glazing Clip
Bead		Manufacturer:	NA
Manufacturer:	Eurocell	Product name:	NA
Product name:	Logik 70 Ovolo Bead	Product code:	NA
Product code:	EWS7312	Glazing tape details	No Glazing Tape
Bead size:	Standard	Manufacturer:	NA
Bead material:	UPVC	Product name:	NA
		Product code:	NA

Hardware				
	Manufacturer:	Product description:	Product code:	Quantity:
Hinges:	Orbit Designs Ltd	20" (508mm) Diamond Link hinge 16.5mm Stack	01-1-20-16.5	1 pair
Hinge fixing: Used during Mechanical Strength testing	Rapierstar	PZ2 4.8 x mm x 60 mm A2 Stainless steel tapping	4.8 mm x 60 mm A2 Stainless steel tapping	16
Hinge fixing: Used during Resistance to Repeat Opening & Closing testing	Rapierstar	PH2-Cheese head Gimlet point-4.8 x 25mm	SFG 4.8 x 25 S	16
Hinge protectors:	NA			
Hinge protector fixings:	NA			
Locking hardware:	ERA	Espagnolette	NA	1
Locking hardware fixing:	NA			
Cylinder:	NA			
Cylinder fixing:	NA			
Handle:	NA			
Handle fixings:	NA			
Touch Bar	NA			
Cylinder Support	NA			
Cylinder Escutcheon	NA			
Keeps:	ERA	Espagnolette keep	NA	3
Keep fixings:	NA			
Drip bar:	NA			
Drip bar fixings:	NA			
Additional Hardware:	NA			

Confirmation

Customer is to confirm that the samples provided for testing are representative of standard production. Please note: the details given above, as well as the drawings supplied by the customer as confirmed as typical of normal production are not verified by UL International (UK) Limited.

Company:	Orbit Designs Ltd
Name:	Terry Dolman
Position:	Design Manager
Date:	30-11-2023

4. Test Arrangement

4.1 Test Rig

The test sample was supplied mounted in a 100 x 75 mm timber sub-frame in accordance with manufacturer's installation requirements. The sample was installed into the test rig, which was constructed to meet the requirements of the test specification, and was installed plumb, square and without twist or bends.

4.2 Instrumentation

4.2.1 Force measurement

Calibrated force gauges and load cells were used to measure operating forces with an accuracy of $\pm 5\%$.

4.2.2 Loading equipment

Weights and/or load cells were used to apply the Mechanical Strength loading with an accuracy of $\pm 2\%$.

4.2.3 Time

A stopwatch was used to measure and record time with an accuracy of $\pm 0.1\%$.

4.2.4 Scales

The mass of the opening leaf was measured using scales accurate to $\pm 2\%$

4.2.5 Torque

A calibrated torque meter was used for recording forces required to operate any finger operated hardware with an accuracy of $\pm 5\%$.

4.2.6 Measuring equipment

Where relevant the following measuring equipment was used:

- A measuring tape and rule accurate to $\pm 0.5\text{mm}$.
- A dial or digital gauge accurate to $\pm 0.01\text{mm}$.

4.2.7 Temperature & humidity

A digital data logger capable of measuring temperature with an accuracy of $\pm 1^\circ\text{C}$ and relative humidity with an accuracy of $\pm 5\%$ were used.

5. Test Procedures

5.1 Sequence of Testing

Sample 1

1. Operating Forces
2. Resistance to Racking
3. Operating Forces
4. Resistance to Static Torsion
5. Operating Forces

Sample 2

6. Operating Forces
7. Resistance to Repeated Opening and Closing
8. Operating Forces

5.2 Resistance to racking

Prior to the test, the window was opened and closed 5 times to an angle of either 90° or its maximum extent in relation to the plane of the frame.

The window vent was opened to an angle of either 90° or its maximum extent in relation to the plane of the frame and a pre-load was then applied to the opening edge corner of the window and held for a period of 60 secs, the load was removed and following a rest period of 60 secs a measurement was recorded at the opposite opening edge corner to that which the load was applied.

The test load was then applied to the same position as that described above and held for a period of 5 mins. On completion of the 5 mins a measurement was recorded at the opposite opening edge corner to that which the load was applied, the load was then removed.

Following a 1-minute period with no load applied to the sample, a further measurement was recorded in order to determine any residual deformation.

5.3 Resistance to static torsion

Prior to the test, the window was opened and closed 5 times to an angle of either 90° or its maximum extent in relation to the plane of the frame as required by the test standard

The window vent was opened to an angle of either 90° or its maximum extent in relation to the plane of the frame and the opposite opening edge corner to that which the load was being applied was locked firmly in position. A pre-load was then applied to the opening edge corner of the window, and held for a period of 60 secs, the load was removed and following a rest period of 60 secs a measurement was recorded at the loading position.

With the opposite opening edge corner to that which the load was being applied locked firmly in position, the test load was then applied to the same loading point and held for a period of 5 mins. On completion of the 5 mins a measurement was recorded at the loading position and the load was then removed.

Following a 1-minute period in which no load was applied to the sample, measurement at the loading position was recorded.

5.4 Operating forces

Prior to the test, all moving parts of the window were operated 5 times as required by the test standard.

The minimum forces, to disengage the hardware, then open and close to/from a distance of 100mm before finally engaging and securing the hardware, was recorded.

The sequence was repeated three times with the results averaged to obtain the final value with a 1 minute rest period between each sequence.

5.5 Resistance to Repeated Opening and Closing

5.5.1 Prior to the test

The mass of the casement, sash or leaf was measured prior to any testing.

With the test sample installed in accordance with clause 6 of EN 1191:2000, the sample was subject to 5 manual operations before the following initial measurements were taken:

- a) The dead load applied by the operating equipment on the casement, sash or leaf
- b) The stroke of the casement, sash or leaf in degrees or millimetres
- c) Dimensions at datum points were taken in order to establish a nominal set of dimensions
- d) The operating forces, measured in accordance with BS EN 12046-1:2003

The cylinders were adjusted in accordance with the operation of the hardware its reference velocity and attainment of forces within the specified limits, the rest times and strokes.

5.5.2 Cyclic test

The test was configured for the correct number of cycles according to the required classification as outlined in BS EN 12400:2002.

At every period equal to 25% of the specified total test cycles (or less if specified by the manufacturer for lubrication) the test was stopped, and the test specimen examined. The test was continued and paused at the examination periods throughout its duration as defined above.

5.5.3 Following the test

Following the completion of the defined number of cycles, the following measurements were taken:

- a) The dead load applied by the operating equipment on the casement, sash or leaf
- b) The stroke of the casement, sash or leaf in degrees or millimetres
- c) Dimensions at datum points were taken in order to establish a nominal set of dimensions
- d) The operating forces, measured in accordance with BS EN 12046-1:2003

6. Test Results

6.1 Lab Conditions

The conditions measured inside the laboratory were as follows:

	Temperature (°C)	Humidity (%RH)
At start of test	18.5	55.3
At completion of test	17.2	54.8

6.2 Operating forces

The results of the tests carried out are as follows:

Description	Operating forces	Classification
Disengage Hardware (N)	12.1	2
Commence Opening (N)	60.3	1
Commence Closing (N)	33.6	1
Engage Hardware (N)	14.2	2
Overall Classification according to BS EN 13115:2001		1

6.3 Resistance to Racking

	Window sash
Test Load (N)	600
Deformation Under Load (mm)	28.69
Residual Deformation Following Test (mm)	5.59

Following the test there were no signs of damage to the sample or loss of functionality.

6.4 Operating forces

The results of the tests carried out are as follows:

Description	Operating forces	Classification
Disengage Hardware (N)	12.3	2
Commence Opening (N)	9.7	2
Commence Closing (N)	23.7	2
Engage Hardware (N)	13.6	2
Overall Classification according to BS EN 13115:2001		2

6.5 Resistance to static torsion

	Window sash
Test Load (N)	300
Deformation Under Load (mm)	19.92
Residual Deformation Following Test (mm)	1.96

Following the test there were no signs of damage to the sample or loss of functionality.

6.6 Operating forces

The results of the tests carried out are as follows:

Description	Operating forces	Classification
Disengage Hardware (N)	12.5	2
Commence Opening (N)	12.9	2
Commence Closing (N)	21.8	2
Engage Hardware (N)	12.1	2
Overall Classification according to BS EN 13115:2001		2

The overall classification for operating forces based on all tests completed before, during and after the Mechanical Strength tests is: **CLASS 1**

6.7 Overall Classification for Mechanical Strength

The overall classification for mechanical strength is: **CLASS 3**

6.8 Resistance to Repeated Opening and Closing

6.8.1 Initial Measurements

Description	Window sash
Mass of leaf (kg)	41.2
Dead load applied by the operating equipment (kg)	0.07
Stroke of casement (°)	70°

The operating forces measured before the test are as follows:

Description	Operating forces	Classification
Disengage Hardware (N)	10.3	2
Commence Opening (N)	16.9	2
Commence Closing (N)	21.1	2
Engage Hardware (N)	14.5	2
Overall Classification according to BS EN 13115:2001		2

6.8.2 Cycle Test

The number of cycles completed by the sample was **20,000** as required by **Class 3** of the standard.

The sample was lubricated as specified by the manufacturer at each period equal to 2500 cycles or 25% whichever the greater and adjustments were carried out as follows:

Hardware was checked and lubricated.

Throughout and immediately following the test, the sample was checked and there were no signs of damage or loss of functionality.

6.8.3 Datum Measurements

Observations and measurement of the datum points were measurement from a point 50mm from each edge of the casement in relation to the outer frame.

Description	Dimension (mm)							
	1	2	3	4	5	6	7	8
Before cyclic test	35.4	35.4	35.4	35.4	35.4	35.4	35.4	35.4
After cyclic test	35.4	35.4	35.4	35.4	35.4	35.4	35.4	35.4
Difference	0.0	0.0	0.0	0.0	0.0	0.0	0.0	0.0

6.8.4 Final Measurements

Description	Window sash
Mass of leaf (kg)	41.2
Dead load applied by the operating equipment (kg)	0.07
Stroke of casement (°)	70°

The operating forces measured following the test are as follows:

Description	Operating forces	Classification
Disengage Hardware (N)	12.6	2
Commence Opening (N)	16.9	2
Commence Closing (N)	21.1	2
Engage Hardware (N)	14.5	2
Overall Classification according to BS EN 13115:2001		2

6.8.5 Variation in Performance

The following calculation is used to assess the variation in performance as a result of the repeated opening and closing test

$$V(\%) = 100 \left(\frac{Pe}{Pi} - 1 \right)$$

V is the percentage variation in performance

Pe is the operating forces measured after the test

Pi is the operating forces measure before the test

Description	Variation in performance (%)
Disengage Hardware	22.7
Commence Opening	-62.8
Commence Closing	-57.4
Engage Hardware	-15.2

The overall classification for repeated opening and closing is: **CLASS 2**

7. System Drawings

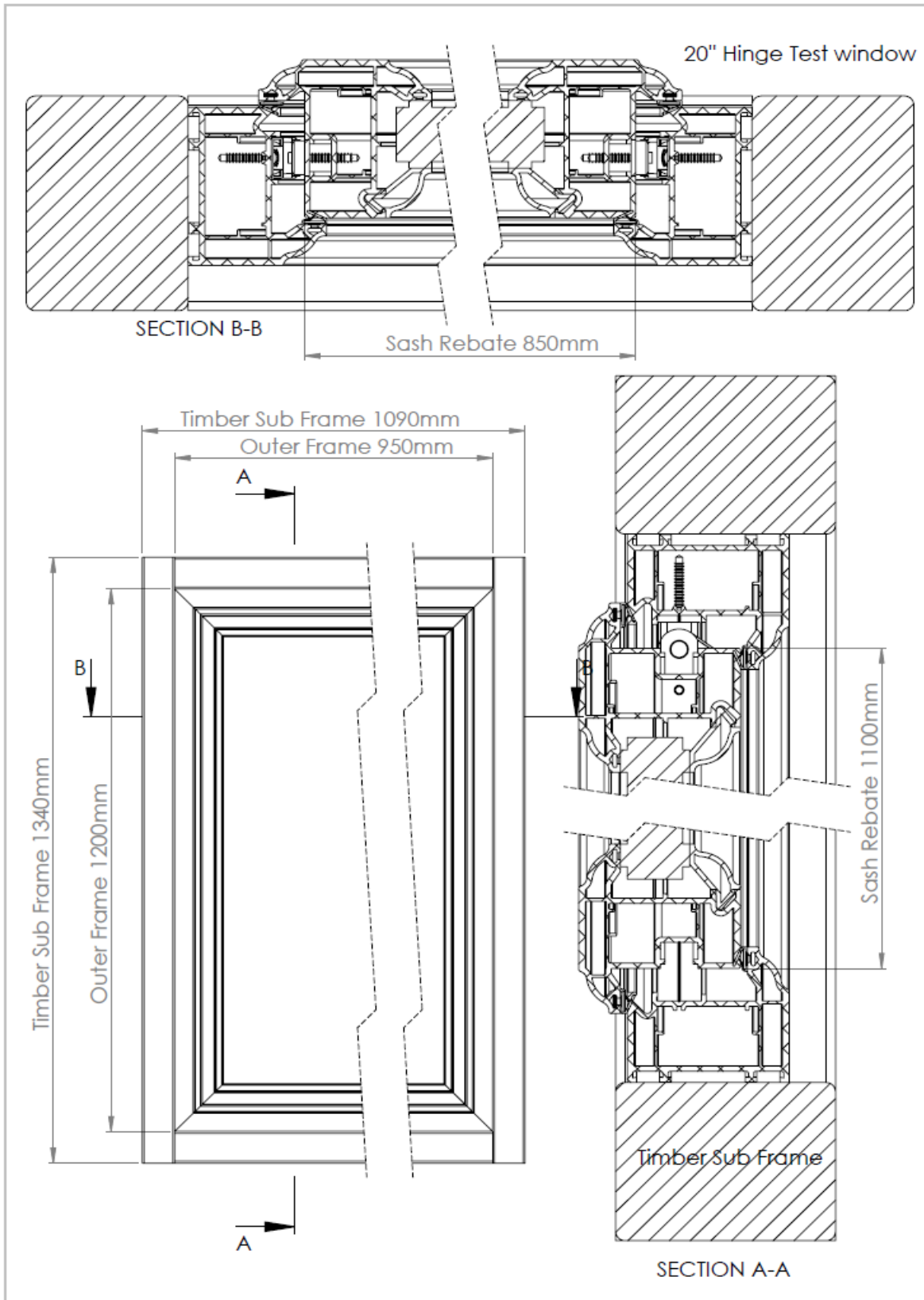

20" HINGE FIXING DETAILS

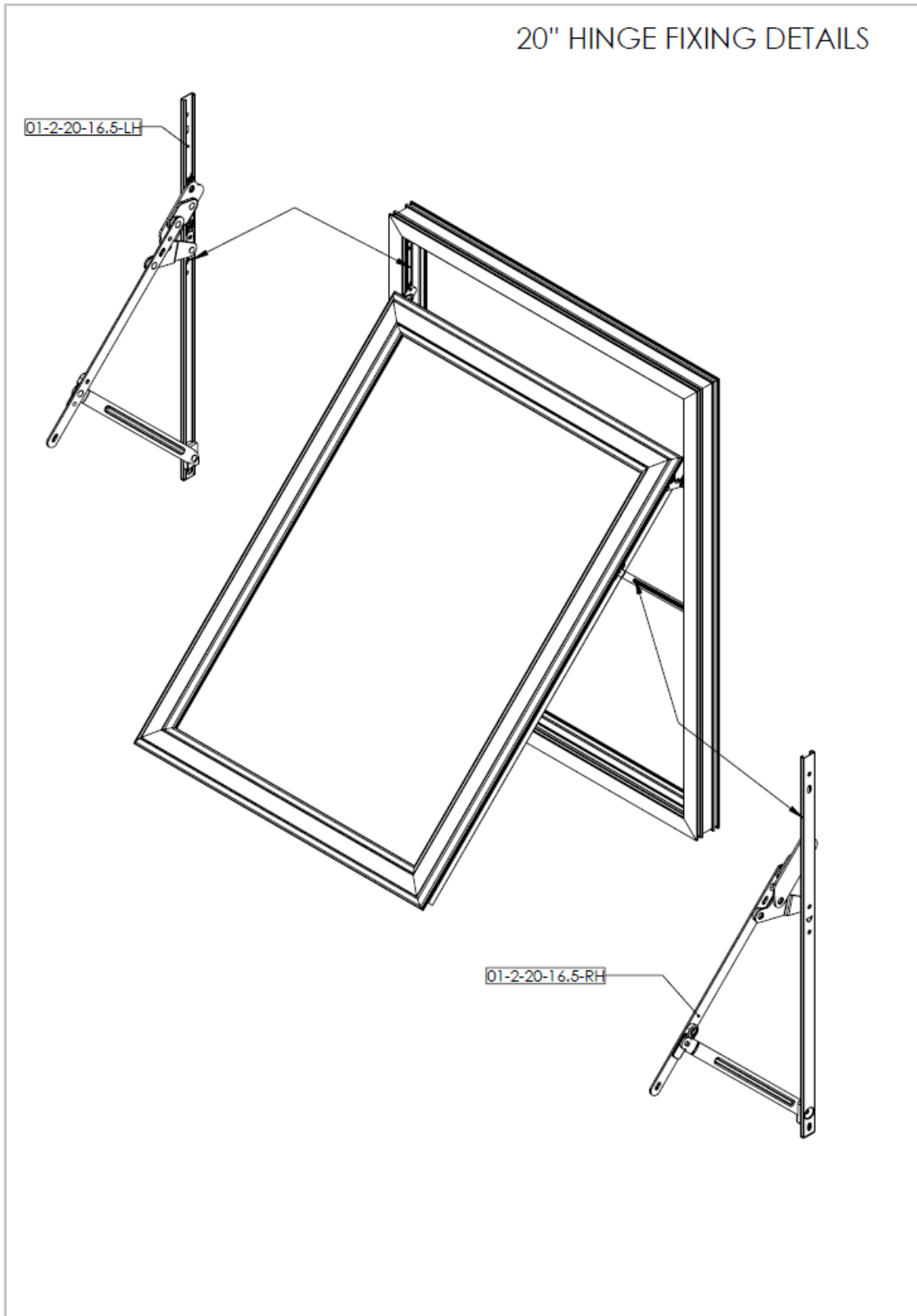

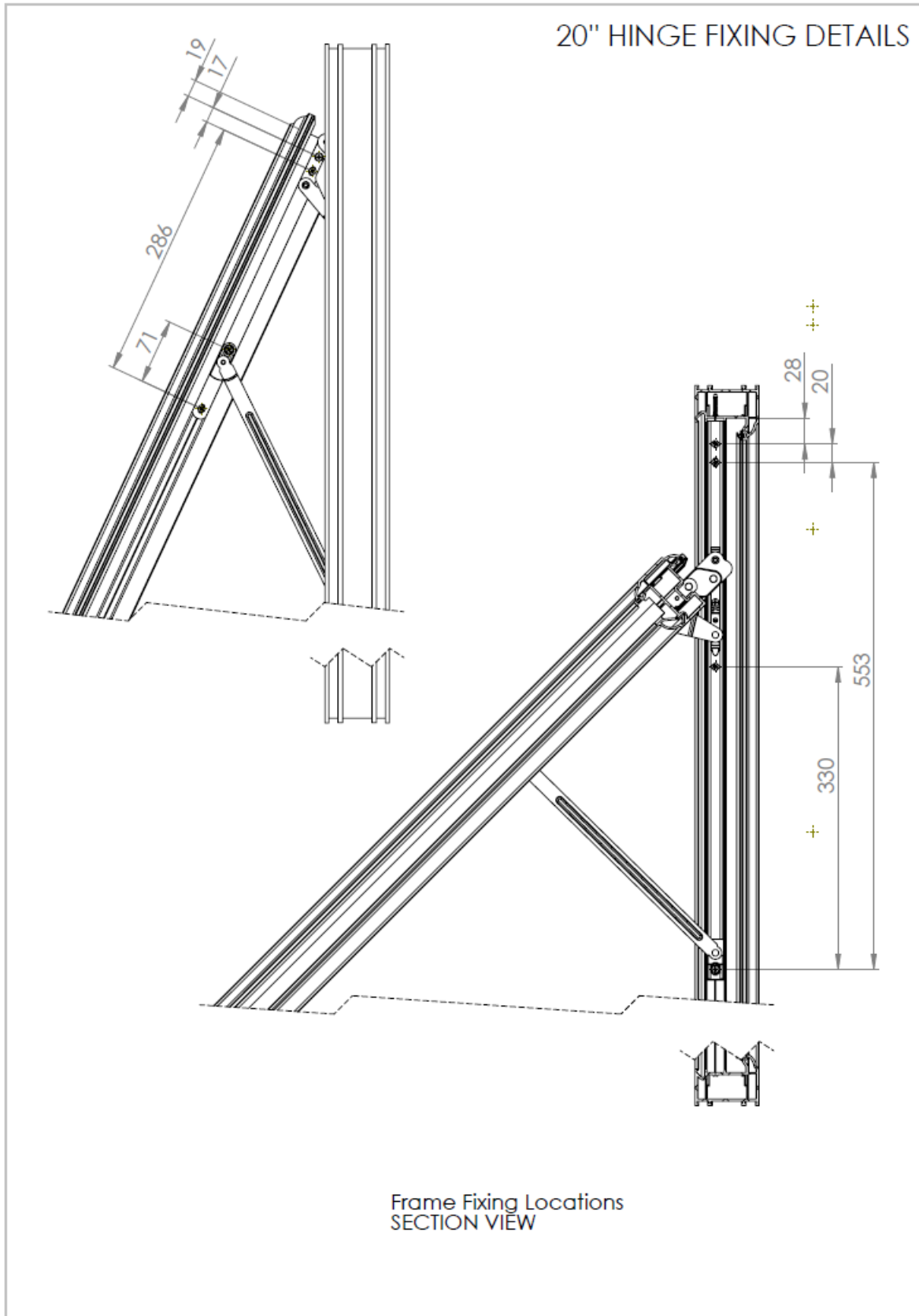



Solutions

TEL 511 Rev 1 – Test Report BS 6375-2:2009
Test Report No: R4791035862
Project No: 4791035862
Date: January 25, 2024

Page 17 of
18

----- END OF REPORT -----





Facade Testing



Onsite Testing



Product Certification



Window & Door Testing

UL International (UK) Limited is an independent UKAS accredited testing laboratory and certification body. We provide a comprehensive range of services to the building and construction industries, either onsite or at our own state-of-the-art test laboratory in Telford, Shropshire, in the heart of industrial England.

 +44 (0) 1952 586580

 www.ul.com